

PARAGON KILN MODEL A-29B WIRING DIAGRAM AND PARTS IDENTIFICATION

The letter "B" following the Model Number means the kiln has a stainless steel jacket.

MODEL A-29B
(4-way Rotary Switches with Push-on Terminals)

TOP SECTION

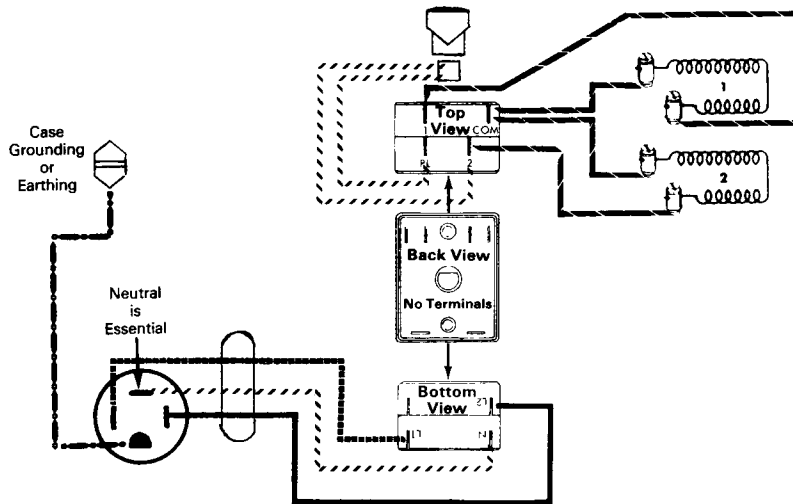

BOTTOM SECTION

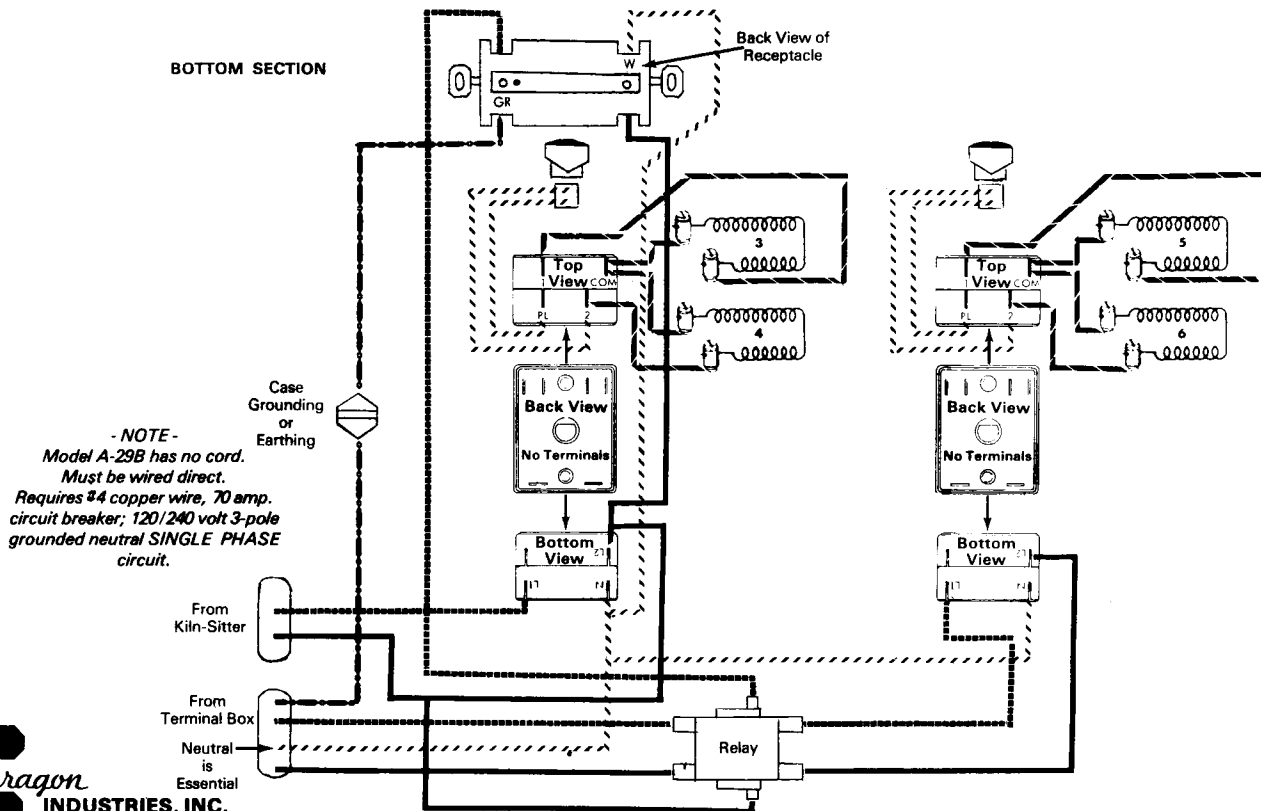

- NOTE -
Model A-29B has no cord.
Must be wired direct.
Requires #4 copper wire, 70 amp.
circuit breaker; 120/240 volt 3-pole
grounded neutral SINGLE PHASE
circuit.

LEGEND

Black ———
Red - - - - -
White / / / / /
Blue ———
or ———
Natural Green - - - - -

Paragon
INDUSTRIES, INC.
BOX 10133
DALLAS, TEXAS 75207

NECESSARY TO FIRE IN WELL-VENTILATED, COVERED AND PROTECTED AREA.

ALL LIDS MUST BE HAND-FITTED
AND DRILLED TO MATCH
HINGE ON KILN, BECAUSE OF VARIATIONS
IN FIRED INSULATING FIREBRICK

PARAGON KILN MODEL A-29B

REF. NO.	PART NO.	DESCRIPTION
METAL JACKET PARTS		
1.	Specify Model	Hinge, complete, gray
2.	Specify Model	Form-Fitted Jacket, stainless, specify section
3.	Specify Model	Full-Formed Steel Base
4.	Specify Model	Heat Shield, specify section
5.	Specify Model	Ventilated Switch Box, metal only, gray specify section
6.	Specify Model	Ventilated Terminal Box, metal only
INSULATING FIREBRICK & BLOCK INSULATION		
7.	BR-11-29	Brick Lid with Band, stainless (less hardware)
8.	BR-2-29	4" Straight Grooved Wall Brick
9.	BR-3-29	4" Terminal Wall Brick
10.	BR-10-29	Brick Bottom, only
11.	Specify Model	Block Insulation
ELECTRICAL PARTS		
12.	EL. A-29	Heating Element for A-29B
13.	WR-18	Switch-to-Element Lead Wires, push-on terminal one end
14.	WR-15 SW-4	Switch, 26 amp. A-21, 4-way Rotary for push-on terminals
15.	MS-7	Pilot Light with Lead Wires, complete
16.	KN-3	Knob for 4-way Rotary Switch A-21, silver center
17.	CR-29	14-4, 240 v., 3 ft. conduit wired, with 4-prong plug and push-on terminals
18.	MS-1	Porcelain Insulators (1 1/8" long)
19.	MS-6	Element Connectors
20.	WR-17	Receptacle-to-Switch Connecting Wires, push-on terminal one end
21.	RC-1	Receptacle, 4-wire, 20 amp., 125/250 v. for kiln's switch box
22.	WR-16	Switch-to-Switch Connecting Wires, push-on terminal both ends
23.	Specify Model	Relay; must give kiln's serial no.
OTHER REPLACEMENT PARTS		
24.	HW-12	Lock-In Lid Support, for large A-series (10 sides or more)
25.	HW-6	Hand Lifts for A-series
26.	ST-5	Kiln Stand
27.	ST-1	Plastic Feet, only
28.	HW-8	#8 Plated Metal Screws
29.	HW-7	Fall Away, Prop-R-Vent Kit
30.	HW-5	Lid Handle, for large A-series
31.	PL-2	Peephole Plug, Cone Shaped for A-series

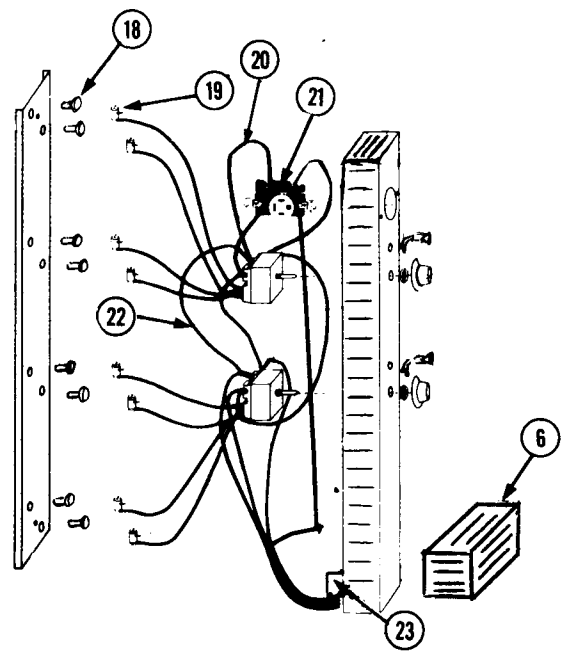
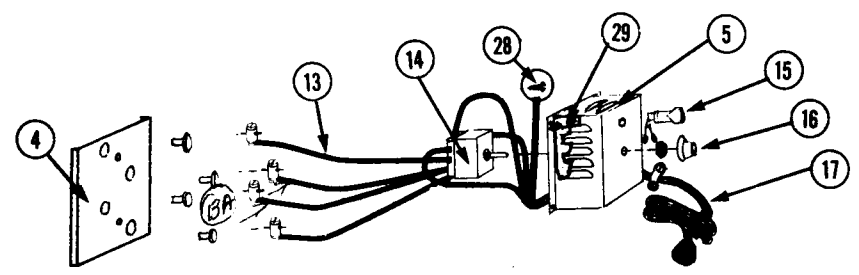
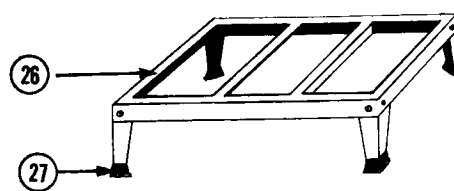
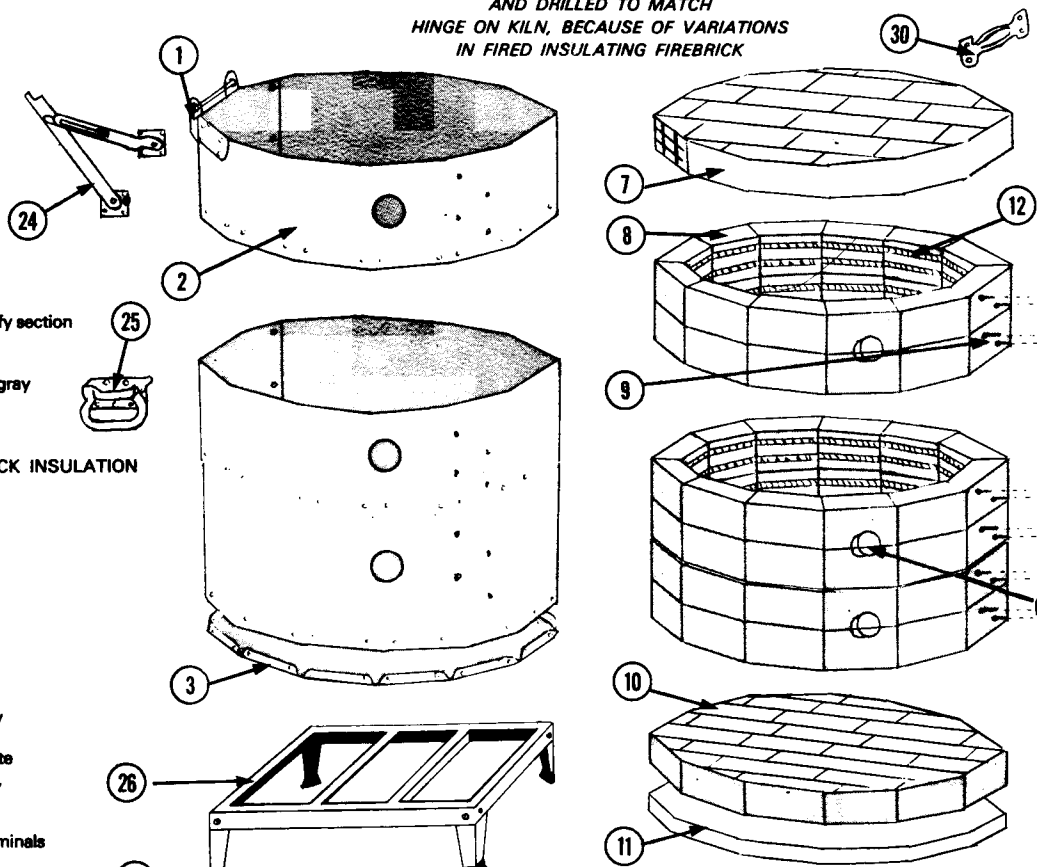

**WHEN ORDERING PARTS,
ALWAYS SPECIFY
MODEL NUMBER,
REFERENCE NUMBER,
PART NUMBER,
AND DESCRIPTION**

For prices of parts, see your current
Paragon Kiln Catalog Price List.
All prices are F.O.B. factory, Dallas County, Texas
and are subject to change without notice.

**MERCHANDISE TO BE SHIPPED TO ONE ADDRESS
ON ONE ORDER MUST TOTAL \$5.00 BEFORE
THE POSTAGE AND HANDLING CHARGES ARE ADDED.**