

DUNCAN EXPORT MODELS DA 820-6F, -6G, -6S

CONTROL PANEL PARTS

REF. NO.	PART NO.	DESCRIPTION
2.	KM 323	2N1 TIMER (240/220V)
3.	KM 330	POWER RELAY (240/220V)
4.	KE 314	#8-32 X 1/2" MACHINE SCREW
5.	KE 322	#8 STAR WASHER
6.	KE 333	#8-32 HEX NUT
7.	KM 385	#1 X 5" FIBERGLASS SLEEVING
8.	KM 342	520,1020/29 CORD STRAIN RELIEF
9.	KE 307	#8-32 X 1 1/4" MACHINE SCREW
10.	KE 328	#8-32 HEX NUT W/WASHER
11.	KE 096	2 POLE TERMINAL STRIP
12.	KC 309	STANDARD BUSS BAR ASSEMBLY
13.	KC 319	U-TERMINAL ASSEMBLY
14.	KE 315	#10-32 X 1 1/2" TAMPERPROOF SCREW
15.	KE 324	#10-32 HEX NUT W/WASHER
16.	KM 309	LID SAFETY SWITCH
17.	KM 383	LID SWITCH MOUNTING KIT
18.	KE 080	INSULATOR
19.	KM 323	820-7/8, 1020 POWER SUPPLY CORD
20.	KM 300	INFINITE SWITCH W/PAL NUT (240/220V)
21.	KM 382	CAPACITOR ASSEMBLY #2
22.	KC 187	6" (15cm) CONNECTING WIRE, 18 GAUGE
23.	KC	10" CONNECTING WIRE, 18 GAUGE
24.	KC 190	6,8 WIRE COMBO, 18 GAUGE
25.	KC 131	1 1/4" (36cm) CONNECTING WIRE, 18 GAUGE
26.	KC 194	PILOT LIGHT ASSEMBLY
27.	KC 139	8" (23cm) CONNECTING WIRE, 12 GAUGE
28.	KM 089	TIMER MOTOR, 50HZ
29.	KC 178	1 1/2" (25cm) CONNECTING WIRE, 12 GAUGE
30.	KC 150	9" (23cm) GROUND WIRE
31.	KC 188	10" (25cm) CONNECTING WIRE, 18 GAUGE
32.	KC 177	6" (15cm) CONNECTING WIRE, 12 GAUGE
33.	KC 138	1 1/4" (36cm) CONNECTING WIRE, 12 GAUGE
34.	KE 095	T-TERMINAL ADAPTER
35.	KE 101	TERMINAL BLOCK ASSEMBLY
36.	KC 061	DIELECTRIC INSULATION FOR KE 101
37.	KC	5" CONNECTING WIRE, 18 GAUGE
38.	KM 381	J POSITION SWITCH

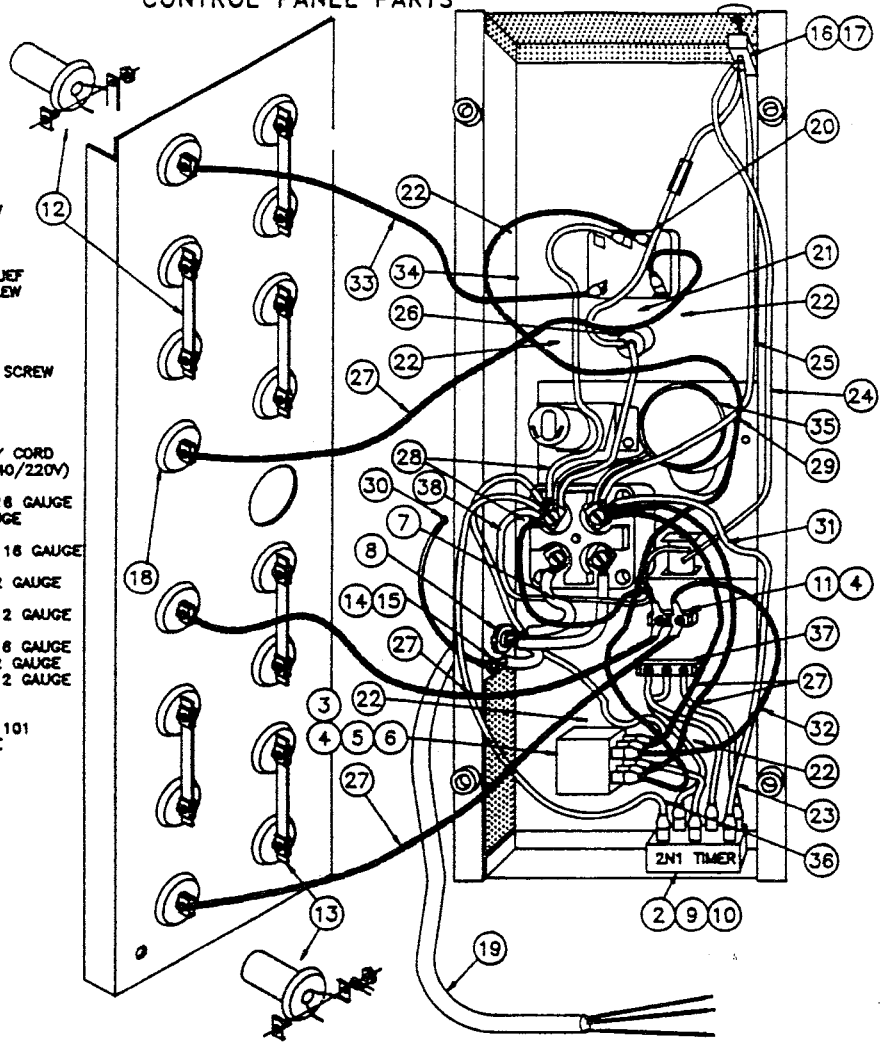

ELECTRICAL SCHEMATIC

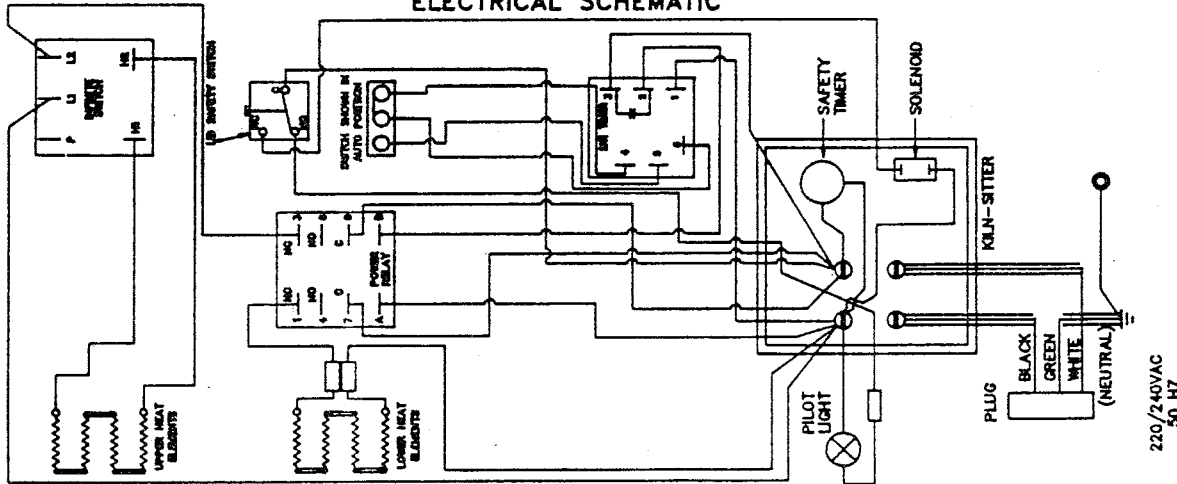

220/240VAC
50 HZ