

DUNCAN MODEL DA 820-8 A

CONTROL PANEL PARTS

REF. NO.	PART NO.	DESCRIPTION
1.	KM 326	4600 REPEAT CYCLE TIMER (240V/220V)
2.	KM 325	4300 FIXED INTERVAL TIMER (240/220V)
3.	KM 324	POWER RELAY (240/220V)
4.	KE 314	#8-32 X 1/2" MACHINE SCREW
5.	KE 322	#8 STAR WASHER
6.	KE 333	#8-32 HEX NUT
7.	KM 365	#1 X 5" FIBERGLASS SLEEVING
8.	KM 342	820,1020/28 CORD STRAIN RELIEF
9.	KE 307	#8-32 X 1 1/4" MACHINE SCREW
10.	KE 329	#8-32 HEX NUT W/WASHER
11.	KE 098	2 POLE TERMINAL STRIP
12.	KC 306	STANDARD BUSS BAR ASSEMBLY
13.	KC 318	U-TERMINAL ASSEMBLY
14.	KE 315	#10-32 X 1/2" TAMPERPROOF SCREW
15.	KE 324	#10-32 HEX NUT W/WASHER
16.	KM 309	LID SAFETY SWITCH
17.	KM 363	LID SWITCH MOUNTING KIT
18.	KE 060	INSULATOR
19.	KM 323	820-7/6, 1020 POWER SUPPLY CORD
20.	KM 300	INFINITE SWITCH W/PAL NUT (240/220V)
21.	KM 362	CAPACITOR ASSEMBLY #2
22.	KC 167	6" (15cm) CONNECTING WIRE, 16 GAUGE
23.	KC 193	10,6,6 WIRE COMBO, 18 GAUGE
24.	KC 190	6,8 WIRE COMBO, 18 GAUGE
25.	KC 131	14" (36cm) CONNECTING WIRE, 15 GAUGE
26.	KC 194	PILOT LIGHT ASSEMBLY
27.	KC 139	9" (23cm) CONNECTING WIRE, 12 GAUGE
28.	KM 089	TIMER MOTOR, 30HZ
29.	KC 178	14" (25cm) CONNECTING WIRE, 12 GAUGE
30.	KC 150	6" (23cm) GROUND WIRE
31.	KC 169	10" (25cm) CONNECTING WIRE, 16 GAUGE
32.	KC 177	6" (15cm) CONNECTING WIRE, 12 GAUGE
33.	KC 138	14" (36cm) CONNECTING WIRE, 12 GAUGE
34.	KE 085	I-TERMINAL ADAPTER
35.	KE 101	TERMINAL BLOCK ASSEMBLY
36.	KC 061	DIELECTRIC INSULATION FOR KE 101
37.	KC 173	8,4 WIRE COMBO, 16 GAUGE
38.	KM 361	J POSITION SWITCH

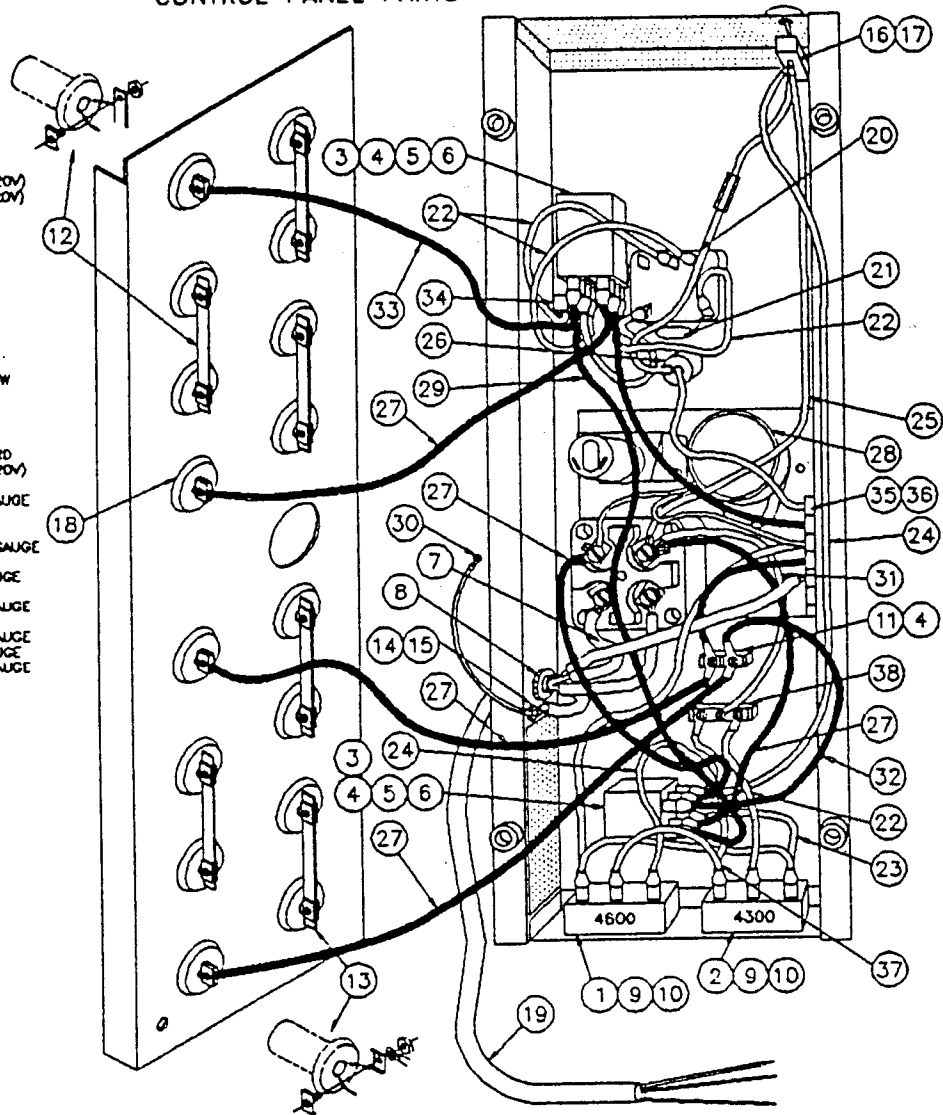

ELECTRICAL SCHEMATIC

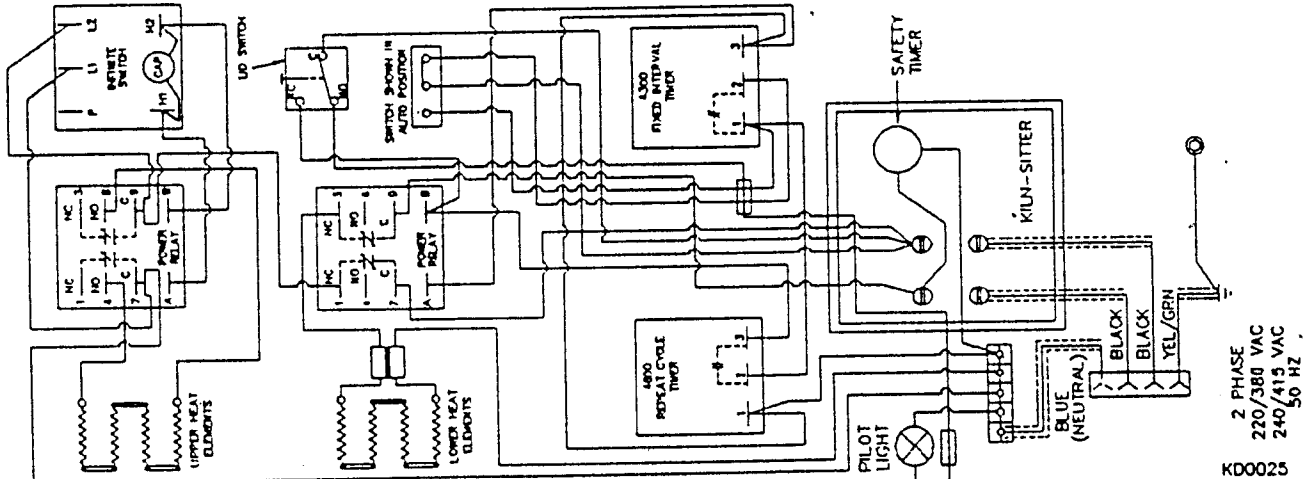

2 PHASE
220/380 VAC
240/415 VAC
50 HZ

KD0025