

# DUNCAN EXPORT MODEL DA 1020-6G

## CONTROL PANEL PARTS

- | REF. NO. | PART NO. | DESCRIPTION                            |
|----------|----------|--|
| 1.       | KM 326   | 4600 Repeat Cycle Timer (240/220V)     |
| 2.       | KM 325   | 4300 Fixed Interval Timer (240/220V)   |
| 3.       | KM 324   | Power Relay (240/220V)                 |
| 4.       | KE 314   | #6-32 X 1/2" Machine Screw             |
| 5.       | KE 322   | #6 Star Washer                         |
| 6.       | KE 333   | #6-32 Hex Nut                          |
| 7.       | KM 385   | #1 x 5" Fiberglass Sleeving            |
| 8.       | KM 342   | 820, 1020/29 Cord Strain Relief        |
| 9.       | KE 307   | #8-32 x 1-1/4" Machine Screw           |
| 10.      | KE 329   | #8-32 Hex Nut w/Washer                 |
| 11.      | KE 098   | 2 Pole Terminal Strip                  |
| 12.      | KC 309   | Standard Buss Bar Assembly             |
| 13.      | KC 319   | U-Terminal Assembly                    |
| 14.      | KE 315   | #10-32 x 1/2" Tamperproof Screw        |
| 15.      | KE 334   | #10-32 Hex Nut w/Washer                |
| 16.      | KM 309   | Lid Safety Switch                      |
| 17.      | KM 363   | Lid Switch Mounting Kit                |
| 18.      | KE 060   | Insulator                              |
| 19.      | KM 323   | 820-7/8 1020 Power Supply Cord         |
| 20.      | KM 300   | Infinite Switch w/Pal Nut (240V/220V)  |
| 21.      | KM 362   | Capacitor Assembly #2                  |
| 22.      | KC 167   | 6' (15 cm) Connecting Wire, 18 Gauge   |
| 23.      | KC 193   | 10,6,6 Wire Combo, 18 Gauge            |
| 24.      | KC 144   | 14' Connecting wire, 18 Gauge          |
| 25.      | KC 131   | 14' (36 cm) Connecting Wire, 18 Gauge  |
| 26.      | KC 194   | Pilot Light Assembly (EA 820-8/1020-6) |
| 27.      | KC 139   | 9' (23 cm) Connecting Wire, 12 Gauge   |
| 28.      | KM 089   | Timer Motor, 50 HZ                     |
| 29.      | KC 178   | 14' (25 cm) Connecting Wire, 12 Gauge  |
| 30.      | KC 150   | 8' (23 cm) Ground Wire                 |
| 31.      | KC 169   | 10' (25 cm) Connecting wire, 16 Gauge  |
| 32.      | KC 177   | 6' (15 cm) Connecting Wire, 12 Gauge   |
| 33.      | KC 138   | 14' (36 cm) Connecting Wire, 12 Gauge  |
| 34.      | KE 095   | T-Terminal Adaptor                     |
| 35.      | KE 101   | Terminal Block Assembly                |
| 36.      | KE 061   | Dielectric Insulation for KE 101       |
| 37.      | KC 173   | 6,4 Wire Combo, 16 Gauge               |
| 38.      | KM 361   | 3 Position Switch                      |
| 39.      | KC 372   | 4' Connecting Wire, 16 Gauge           |

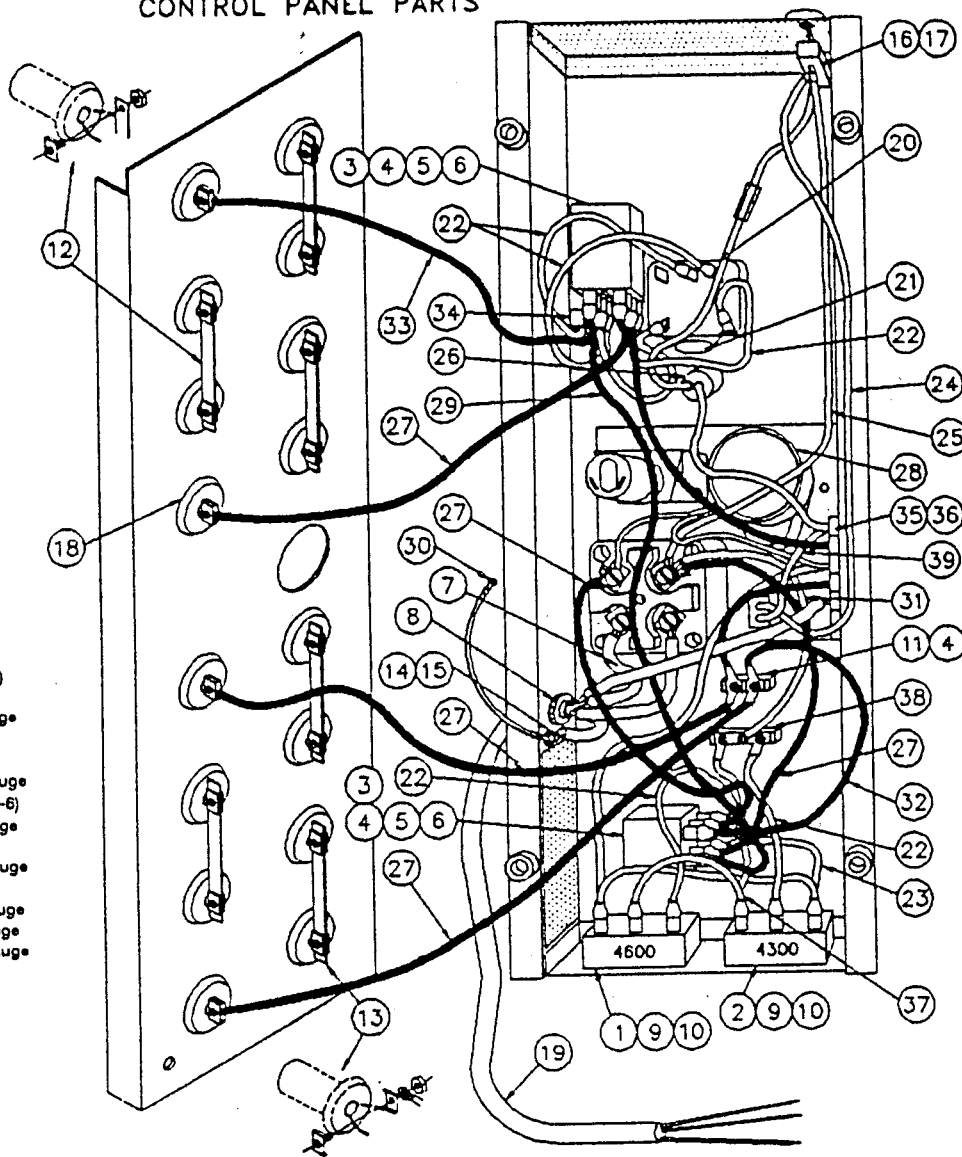

## ELECTRICAL SCHEMATIC

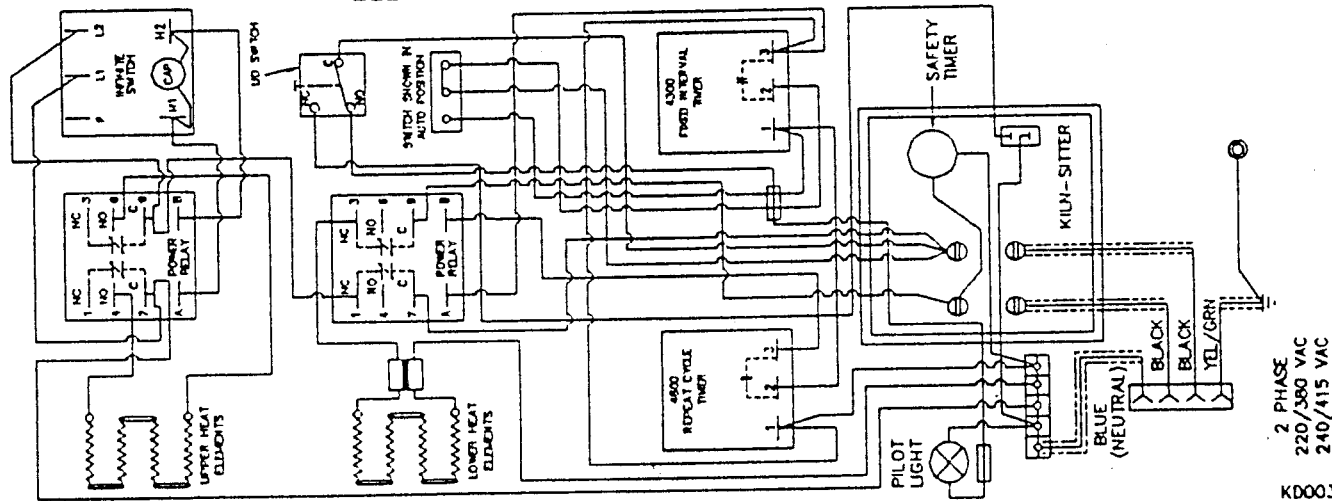

2 PHASE  
220/380 VAC  
240/415 VAC  
50 HZ

KD0037